

Panasonic

SPRING 2011

HOME APPLIANCES AND
PERSONAL CARE CATALOGUE

LIVE THE
WORLD
YOUR WAY



MAJOR DOMESTIC APPLIANCES



MICROWAVES



SMALL APPLIANCES



PERSONAL CARE



More Time for Enjoyment

Panasonic home appliances not only make daily tasks and personal care easy and less stressful, they also save you time for the more important things in life – like sharing precious moments with family and friends.



Eco-Friendly Features and Easy-to-Use Products Go Hand in Hand

Panasonic has been globally committed to developing products that are environmentally friendly. In particular, Panasonic is striving to deliver products which incorporate the latest energy-efficient technologies, enabling consumers to support our planet and make a difference in the world. Refrigerators and washing machines, kitchen and cleaning appliances, men's grooming products and women's beauty care – Panasonic offers you a wide range of simple yet innovative products for today's modern and active lifestyle.



REFRIGERATOR	04 – 17
Introduction	04 – 09
Side-by-Side Refrigerator	10 – 13
2-Door Refrigerator	14 – 17



MEN'S SHAVER	46 – 53
Introduction	46 – 48
Special Features	49
4-Blade Shaver	50 – 51
3-Blade Shaver	52 – 53
2-Blade Shaver	53



WASHING MACHINE	18 – 27
Introduction	18 – 19
Special Features	20 – 25
Front Load	26 – 27



GROOMING	54 – 57
Introduction	54
Special Features	55
Hair Clipper	56
Beard Trimmer	56
Body Shaver	57
Facial Hair Trimmer	57



MICROWAVE	28 – 37
Introduction	28
Special Features	29
Combi Microwave	30 – 32
Slimline Combi Microwave	33
Grill Microwave Oven	34
Microwave Oven Only	35 – 37



DEPILATION	58 – 62
Introduction	58 – 59
Epilator	60 – 61
Shaver	62
Facial Hair Trimmer	62



BREADMAKER	38 – 39
Introduction	38
Breadmaker	39
Special Features	39



BEAUTY CARE	63
Hair Styler	63



VACUUM CLEANER	40 – 45
Special Features	40 – 41
Bagless Upright Cleaner	42 – 43
Bagged Upright Cleaner	44
Bagged Cylinder Cleaner	45

SPECIFICATIONS	64 – 74
-----------------------	----------------

Fresh Food for the Whole Family

Panasonic refrigerators not only stylishly blend in with your lifestyle and kitchen décor, they also integrate a host of technology which preserves the freshness of food for longer and ensures eco-friendly operation.





Eco-Friendly Cooling Performance

Kind to the environment and comfortable for you, Panasonic side-by-side refrigerators are packed with innovative cooling technologies which help you save energy and ensure low noise operation.



Successful Heritage in Home Appliances

Panasonic is not just an expert in consumer electronics, but home appliances too. Panasonic washing machines and refrigerators have been hard at work all around the world since the early 1950s. That means Panasonic has over half a century of experience in developing innovative products that fit consumers modern lifestyles.



Top Level Energy Savings

Thanks to the smart combination of Inverter, U-Vacua and Twin-Eco Cooling technologies, Panasonic side-by-side refrigerators achieve the excellent energy label rating of A++. That means refrigerators that feature full No Frost consume much less energy than conventional models.

Only the NR-B53V1 has an A++ energy label, the NR-B54X1 has A+.



Energy Efficient Power

Conventional refrigerators have just one power level, but new Panasonic refrigerators with Inverter technology have various power levels to ensure the most efficient use of energy. A microprocessor intelligently detects the refrigerator's temperature. Then, based on this information, the compressor adjusts the Inverter motor's rotation speed. This means that the amount of power generated is optimally adapted to suit cooling needs and maintain the ideal temperature. At night the refrigerator works at a low power level and quickly freezes items if you need to, it can generate extra power.

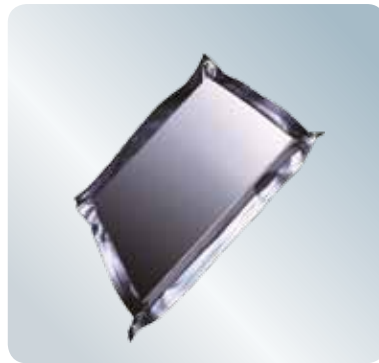

Effective Insulation

Traditional insulation requires more material for better performance. To reduce the use of resources, Panasonic refrigerators feature the effective U-Vacua panel. Glass-fibres, processed in a vacuum, produce an ultra thin sheet which provides 20 times more insulation than traditional materials. The result is higher energy efficiency, a reduction in the amount of materials needed and more space in the freezer for all your food.



Eco-Friendly Cooling

The majority of a refrigerator's energy is used to cool the freezer, so you want it to be as efficient as possible. To ensure this, Panasonic Twin-Eco Cooling has an EcoValve to close off the cooling circuit for the refrigerator, so it can concentrate on the cooling needs for the freezer providing eco-friendly cooling only where it is needed. This saves energy compared to traditional twin cooling systems, which always cools both the fridge and freezer, even if it is not needed in the refrigerator.

Quiet Operation

Panasonic refrigerators stand out from the rest, especially thanks to their low noise operation which is made possible by the Inverter technology. At just a whisper quiet 36dB¹, they are some of the quietest in their class. So quiet, you will not even notice the refrigerator is there.

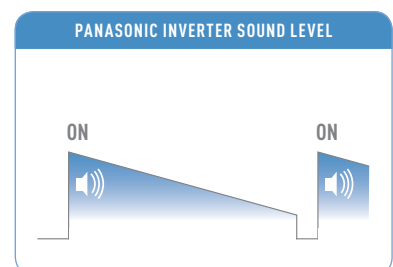
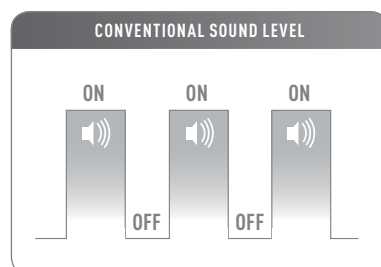

¹ The NR-B32FX2 and NR-B32FW2 operate at 36dB.



Keep Food at its Best – Cutting-Edge features by Panasonic Keep Your Food Fresh for Longer.



Vitamin-Safe Compartment for Freshness

Conventional refrigerators are normally too dry for storing fruit and vegetables, as they rely on the air inside the entire appliance. But not Panasonic. These modern refrigerators feature the Vitamin-Safe compartment, which is optimised to a high humidity level. The temperature can also be adjusted between 0°C and 5°C to ensure your fruit and vegetables stay fresh for longer.

LEDs for Vitamin Rich Produce

Fruit and vegetables stored in the dark lose vitamins. To prevent this, the Vitamin-Safe compartment features two flashing LEDs which simulate the blue and green hues of sunlight. The LEDs activate the fruit and vegetables natural defences and stop them from losing vitamins. This positive effect has been tested and certified by SLG, a renowned independent test laboratory.

Approved by SLG Prüf- und Zertifizierungs GmbH, certifying the 'optimisation of the storing system by using Vitamin-Safe' (SLG is a renowned independent test laboratory).



Keep-Fresh Compartments

0°C Fresh Case: Chilling temperatures and low humidity are ideal for storing fish and meat.

Vitamin-Safe Compartment*: High humidity, adjustable temperature from 0°C to 5°C and LEDs to retain vitamins.

5°C Freshzone: High humidity, fixed temperature at 5°C and LEDs to retain vitamins for root vegetables and other produce sensitive to low temperatures.



*Featured on models: NR-B53V1, NR-B32FX2 and NR-B32FW2.



Always Enjoy Fresh Food

Panasonic refrigerators feature advanced technologies which preserve the freshness of your food for longer. From the convenient Vitamin-Safe compartment to the Hygiene Active system, they contribute to an all-round healthy lifestyle.

hygieneactive

Keep Your Food Safe

The Panasonic Hygiene Active system is a combination of technologies which protect your food from coming into contact with harmful bacteria. Used in various products, silver is traditionally known for its antibacterial properties. The combination of a silver filter, which produces silver ions, as well as water mist and blue LED light, forms an anti-bacterial cleanser called 'Hydroxy Radical', which naturally occurs in the troposphere. This natural effect is produced inside a Panasonic refrigerator, eliminating 99.9999%¹ of harmful bacteria.

¹ Figure based on the ISO 22196 testing measure.

Clean Air Circulation

The Hygiene Active system is placed at the back of the refrigerator in the centre of the cooling airflow. At three different points, the cold and clean air is blown into the refrigerator to create a constant airflow and ensure maximum hygiene.

Approved by SLG Prüf- und Zertifizierungs GmbH, certifying the 'optimisation of the air by using Hygiene Active' (SLG is a renowned independent test laboratory).



Hygiene Active system comprised of a silver filter and blue LED



NR-B53V1



- Energy Efficiency A++ with No Frost Technology
- Twin-Eco Cooling, Inverter Compressor and U-Vacua Vacuum Insulation Panel
- 346kWh Annual Energy Consumption (actual energy consumption will vary depending on use and location)
- 530 Litre Net Capacity
- 324 Litre Refrigerator Net Capacity
- 206 Litre Freezer Net Capacity
- 38dB Quiet Operation
- Touch-Control Display
- Functional Interior Design
- Stylish Stainless Steel

vitaminsafe **hygieneactive** **twin-ecocooling**



NR-B54X1



- Energy Efficiency A+ with No Frost Technology
- Twin-Eco Cooling and Inverter Compressor
- 398kWh Annual Energy Consumption (actual energy consumption will vary depending on use and location)
- 545 Litre Net Capacity
- 339 Litre Refrigerator Net Capacity
- 206 Litre Freezer Net Capacity
- 38dB Quiet Operation
- Half Mirror LED Display
- Arctic White

hygieneactive **twin-ecocooling**

INVERTER **anti fingerprint** **vitaminsafe** **hygieneactive** **twin-ecocooling** **5°C freshzone**

NR-B53V1	•	•	•	•	•	•
NR-B54X1	•			•	•	•

Modern Design and Convenient Features

Panasonic side-by-side refrigerators not only offer intelligent storage solutions, they are sure to blend into any kitchen décor thanks to a modern, no handle design.



anti fingerprint

The special 'Anti-Fingerprint' coating on the stainless steel finish ensures that the refrigerator maintains its stylish look, so you do not have to hassle with constantly cleaning it. The surface is specially treated to resist fingerprints, even when touched by soiled fingers.¹

¹ NR-B53V1 only.



Ice/Water Dispenser

These refrigerators feature a modern ice/water dispenser. At just a single press on the LED display panel, you have water, ice cubes or crushed ice. The elegant stainless steel lever and blue LED light make it not only easy to use, but an eye-catcher in your kitchen too.



LED Lighting

Thanks to LED tower lighting that brightly illuminates the refrigerator from the sides, you will clearly see everything in the fridge. Plus, LEDs use much less electricity.

Easy-to-Use Half Mirror Touch Panel

The innovative control panel is used to adjust temperature, select options like 'Super Freeze' and 'Eco Cooling' and is situated in the centre between the doors. Plus, the ice/water dispenser has its own stylish LED panel to select water or ice. The touch control panel is not only highly modern, with the half mirror finish it is also a visual highlight.

High Power Level The compressor is running at high speed.



Lowest Power Level The compressor is shut down or running at its lowest speed.



Temperature Setting Buttons Let you change the temperature settings for each compartment separately using one-touch buttons.

Vitamin-Safe The LEDs in the fruit and vegetables compartment illuminate, and the vitamin-saving function is activated.¹

Super Freeze You can use this setting when you want to quick freeze items. It can operate continuously for up to 50 hours.

Hygiene Active This enables you to activate the Hygiene Active system at the touch of a button.

Eco Mode Changes the temperature for all three compartments to the most energy efficient.

Alarm / Child Lock You can turn off the alarm, which sounds if the door is left open or there are any abnormalities in temperature. Press and hold the 'Lock' button to activate 'Child Lock'.

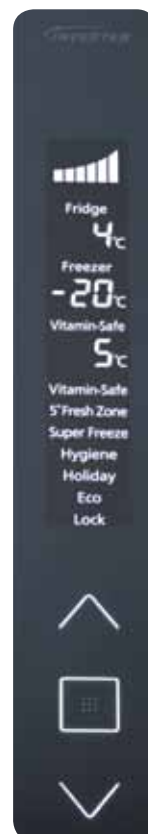

¹ NR-B53V1 only.



4

7

1

8

2

6

5

3

Perfect Storage Solution

With a contemporary and eye-catching design, Panasonic side-by-side refrigerators shine with plenty of ideal storage space for all your groceries as well as with convenient features that make life easier.

Plenty of Space Throughout

In a new Panasonic side-by-side refrigerator, there is a spot for everything. Long door pockets, adjustable tempered glass shelves, a range of practical deep compartments and enough room to easily fit a weeks worth of groceries. All your food is optimally stored and easy to find.

- 1 **Spacious Door Pocket** You have enough room for all kinds of bottles. The smart bottle stopper keeps smaller bottles right in place.
- 2 **Adjustable Shelves** Adjustable tempered glass shelves can hold up to 100kg, making them strong enough for heavy pots.
- 3 **Optimal Storage** These drawers feature 3 different temperature and humidity levels to provide optimum storage for various foods and produce. The 0°C compartment is ideal for fish and meat, while the Vitamin-Safe and 5°C freshzone drawers perfectly store all your fresh fruit and vegetables.
- 4 **Compact Icemaker** The space-saving icemaker frees up more room inside the freezer.
- 5 **Large Compartments** Three large compartments easily hold a range of large bags such as peas or chips.
- 6 **Deli Case** The right place for sliced meat, cheese and sushi (only available with the NR-B53V1).
- 7 **Wine Rack** The adjustable, full width wine rack holds up to 5 bottles.
- 8 **Extra Wide Freezer** So you can get the most out of your freezer space, Panasonic side-by-side refrigerators feature a 30cm wide freezer. It gives you 206 litres of capacity, with shelving and three big compartments – all in all, enough space for large items like frozen pizza boxes.



- 7 **Wine Rack** The adjustable, full width wine rack holds up to 5 bottles.





NR-B32FX2

- **Energy Efficiency A+++ with Full No Frost Cooling Technology**
- **249kWh Annual Energy Consumption**
(actual energy consumption will vary depending on use and location)
- **315 Litre Net Capacity**
- 225 Litre Refrigerator Net Capacity
- 90 Litre Freezer Net Capacity
- 36dB Super Quiet Operation
- Inverter Compressor: Most Efficient Use of Energy
- Special Features: Child Lock, Holiday Mode and Eco Mode
- LED Interior Light
- LED Display
- Stylish Stainless Steel

Colour:

NR-B32FW2

- **Same Features as NR-B32FX2**
(except Anti-Fingerprint finish)
- **Available in Arctic White**

vitaminsafe **hygieneactive** **anti fingerprint**

INVERTER anti fingerprint vitaminsafe hygieneactive

NR-B32FX2	•	•	•	•
NR-B32FW2	•		•	•

Energy Savings with Quiet Operation

Highly energy efficient with super quiet operation, these Panasonic 2-door bottom-freezer refrigerators meet your family's everyday needs, thanks to clever technology and modern features.



Stylish Half Mirror Panel

The half mirror finish of the LED control panel is an eye-catcher in any kitchen and it is extremely easy and intuitive to use.



anti fingerprint

The special 'Anti-Fingerprint' coating on the stainless steel finish ensures that the refrigerator maintains its stylish look, so you do not have to hassle with constantly cleaning it. The surface is specially treated to resist fingerprints, even when touched by soiled fingers.¹

¹ NR-B32FX2 only.



Full Length Aluminium Handle

Perfect for small children or tall adults, the full length handle is made of high quality, robust aluminium. It also seamlessly blends in with the refrigerator's exterior design, adding to the style of any modern kitchen décor.

Easy-to-Use Half Mirror Panel

The sleek and intuitive one-touch panel on the front of the refrigerator lets you quickly select or change temperature settings.

Inverter Power Indicator Gives a visual indication of the Inverter's current energy consumption.

High Power Level The compressor is running at high speed.



Lowest Power Level The compressor is shut down or running at its lowest speed.



Temperature Indicator Shows you the temperature settings and current temperature for each compartment.

Temperature Setting Buttons Let you change the temperature settings for each compartment separately using one-touch buttons.

Vitamin-Safe The LEDs in the fruit and vegetables compartment illuminate, and the vitamin-saving function is activated.

Super Freeze You can use this setting when you want to quick freeze items. It can operate continuously for up to 50 hours.

Hygiene Active This enables you to activate the Hygiene Active system at the touch of a button.

Eco Mode Changes the temperature for all three compartments for energy efficiency.

Alarm / Child Lock You can turn off the alarm, which sounds if the door is left open or there are any abnormalities in temperature. Press and hold the 'Lock' button to activate 'Child Lock'.

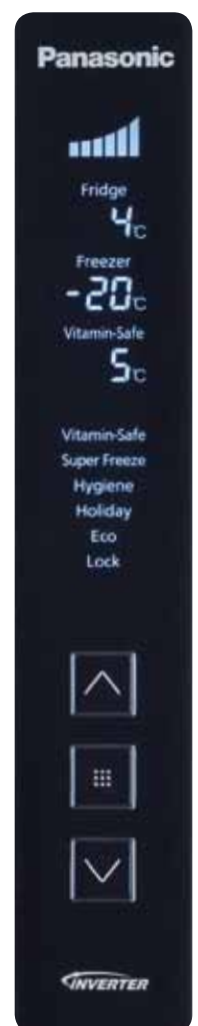



Efficient Storage & User-Friendly Features

Every detail of a Panasonic 2-door refrigerator has been carefully considered to offer you optimum performance, large storage capacities and all-round user convenience.

Smart Features for Convenient Use

Panasonic 2-door refrigerators offer you all of these great features and a stylish design to match. From stay-fresh compartments to adjustable shelves and larger freezer capacity, these refrigerators are sure to fit into your active lifestyle.

1 LED Prismatic Lighting Eight LED lights contribute to uniform light distribution, making it easy to see what is stored inside the refrigerator.

2 Adjustable Tempered Glass Shelves The four adjustable glass shelves are tempered for hot pots or pans and let you organise the space in the refrigerator as you like.

3 Full Size Wine Rack This removable wine rack holds five full size bottles.



4 Fresh Case A special compartment with low temperature and low humidity – ideal for storing meat and fish or defrosting frozen food slowly and safely.

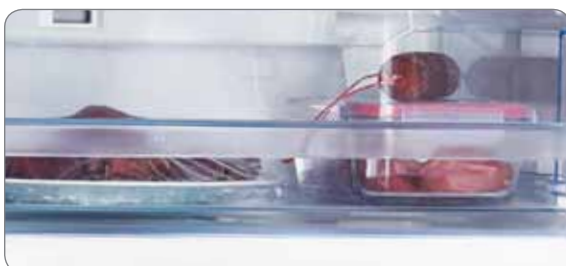

5 Vitamin-Safe Compartment To keep your food fresh for longer, this high humidity compartment (temperature independently adjustable from 0°C to 5°C) prevents your fruits and vegetables from drying out.



6 Large Freezer Capacity The freezer offers plenty of space. It can hold up to 90 Litres, perfect for large items with enough room to easily store three big frozen pizza boxes.



No Frost



Thanks to the Full No Frost function, you do not need to defrost the refrigerator or freezer anymore and your electricity bills remain low.



A woman with long brown hair, wearing a white tank top and grey pants, is walking in a modern bathroom. She is looking out a large window that offers a view of a lake and a sandy beach. The bathroom features a white bathtub, a glass shower door, and a grey rug. The scene is brightly lit, suggesting a sunny day.

Enjoy Perfect Laundry Care

Panasonic washing machines clean perfectly and care for your clothes. Efficient washing programmes and quiet operation enable you to have more flexibility in your life, while their eco-friendly features save both water and energy.

Smart Choice for Energy Savings

The newest Panasonic washing machines are kind to the environment in two ways, they save both precious energy and water helping you to make a difference.

Key Technologies for Saving Energy

Eco-Friendly – A+++ Energy Efficiency



Panasonic has developed a range of innovative, highly efficient technologies, so you can save as much energy and water as possible with every wash. The 3D sensor, Perfect Sense, HydroActive+ and Inverter motor all work together perfectly to ensure clean results and the best possible resource savings in equal measure. Plus, they provide quiet operation for a more enjoyable washing experience.

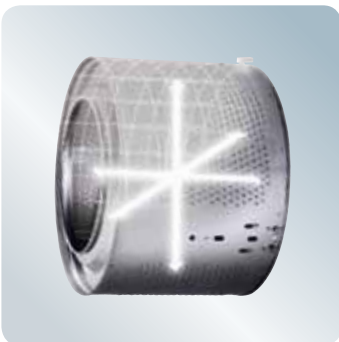

Sensible Washing

The innovative 3D sensor by Panasonic precisely measures the amount of clothes inside the drum, then communicates this information to Perfect Sense, which optimally adapts the energy and water needed. This not only ensures precious resources are not wasted, but also the best possible washing performance regardless of the size of the load.

Perfect for Any Load



Thanks to Perfect Sense technology by Panasonic, you can save energy and water whenever you do the washing. The 3D sensor precisely detects the amount of clothing inside the drum for optimum washing – and Perfect Sense ensures that the water and energy consumption are reduced according to the size of the load.



5 Star - Speedy Results with HydroActive+



Complementing the other energy saving features, HydroActive+ uses five multi-directional showers to ensure the most efficient washing possible. These showers rapidly deliver water to fully dissolve the detergent into the wash and provide thorough rinsing, resulting in less time and energy used.

Built to Last



The innovative Inverter motor inside many Panasonic washing machines receives information from the 3D sensor to determine the number of drum rotations needed. This enables the motor to work most efficiently according to the size of the load and also to ensure energy savings. Not only does the Inverter motor come with a ten year warranty, it is brushless making the motor extremely quiet for a more comfortable washing experience.

Available upon purchase of the following qualifying Panasonic washing machines: NA-140VG3, NA-168VG3, NA-148VG3.

Choose the Ideal Setting to Save Energy

Designed for Your Lifestyle



With a top-of-the-line Panasonic washing machine, you have 'Eco Speed' mode giving you three choices as to how you want to do your washing. Select 'Normal Wash' for efficient washing with normal energy consumption – or 'Speed Wash' for shorter washing times. The 'Eco Wash' is great if you want to take advantage of resource saving washing and do not mind waiting a bit longer for your clean clothes.

	Normal Wash	Speed Wash	Eco Wash
Energy			50% energy saving ¹ 30% water saving ¹
Time		40% time saving ¹	

¹ In-house test result, 8kg of laundry washed using 8kg capacity model set to 'Cotton 60°C' programme.

Super Low 15°C Washing



The lower the washing temperature, the more energy you save. That is why Panasonic washing machines feature the '15°C Wash' cycle, which lets you wash your clothes at a super low 15°C. They come out perfectly clean and you save energy!

Panasonic recommends using a highly concentrated liquid detergent.

Automatic Savings



Panasonic washing machines with 'Auto Power Off' save energy even when the cycle is complete. The machine automatically turns the power off once the washing programme has completed.



Easy and Comfortable in Every Way

From the drum inside to the outside design, every Panasonic washing machine has been specially constructed to deliver maximum results and user convenience.

Design Meets Performance and Quiet Operation



Conventional Drum



New Sazanami Drum

Washing More Quietly



Because you do not want the washing machine to disturb you, Panasonic has specially engineered the Silent Arch design. Integrated into the sides of the appliance, the Silent Arch design effectively absorbs sounds which the machine naturally makes during the washing process, reducing harsh noise and vibrations. In addition, vibrations generated when the drum rotates are dispersed to ensure a quieter cycle.

Washing More Gently



The newly designed Sazanami drum features an interior with dimple-shaped water spouts, ideal for thoroughly removing dirt while being kind to your clothes. The rounded edged dimples not only allow for fewer holes and less bumps than a conventional drum, they also prevent clothes from catching. This unique design also provides a high spin drying performance.

NA-140VG3/168VG3/148VG3 noise level during wash cycle is 53dB.

NA-127VB3/148VB3/147VB3/128VB3 noise level during wash cycle is 58dB.



Large Capacities and Quick Programmes Ensure Comfort



Convenience and Ease of Use Go Hand in Hand

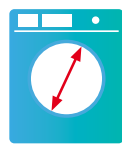

The capacity of the drum for the new NA-140VG3 Panasonic washing machine can handle up to 10kg, making it possible to wash up to 50 shirts. Plus, the wide door opening makes it easy for you to load and unload the machine. If you do not need the full capacity there is no need to worry about consumption. Thanks to the Perfect Sense technology, the amount of water and energy is automatically adapted to the amount of clothes. When you are tight on time, this washing machine features a 'Quick 50' programme and 'Speed' mode too.

Built to Last – Robust and Reliable



Long-Term Durability Test

Panasonic focuses on achieving long-term durability. To ensure this, we conduct a durability test with 5,000 wash cycle repetitions, a battery of other operating tests under conditions such as high temperature/high humidity and low temperature operation, and 24 hour continuous washing and high temperature cycles. Assuming that the average number of home laundry operations is 220 times a year, rigorous testing simulates about 23 years of use.*

*Test conditions for the G Series.



Protection from Water Damage

The Water Leakage Protection system is a Panasonic original safety system that ensures water tight, safe operation. When water is filling the drum and draining out, sensors detect if there is any leakage and respond by not allowing any more water to enter the machine.

Safety First



The 'Child Lock' function keeps the door firmly locked so that it cannot be opened while the machine is running. Plus, it locks the buttons to prevent children from changing programmes.

A Programme for Every Fabric

Whatever clothes are being washed, Panasonic washing machines offer a host of customised care programmes to deliver perfect results in less time using less energy.



Special Programmes

Here is a quick overview of even more custom fabric care and wash programmes. No matter what your laundry needs, a Panasonic washing machine has just the right solution.



Quick 50 A 50 minute programme for lightly soiled items.



Bedding For large items like duvets, blankets or curtains.



Delicates For wool, satin, lace and other delicate fabrics.



Rapid 15 A 15 minute programme to refresh small loads of laundry.



15°C Wash Eco-friendly, thorough washing at a low temperature of 15°C.



Memory Saves the favourite wash programme for quick, one-touch start.

Navigator

	NA-140VG3	NA-168VG3	NA-148VG3	NA-148VB3	NA-147VB3	NA-127VB3
Mixed	•					
Silk/Lingerie	•					
Outdoor		•	•			
Denim		•	•			
Shirts	•	•	•	•	•	•
Sportswear	•	•	•	•	•	•
Baby Care	•					
Easy Care	•	•	•	•	•	•
Wool	•	•	•	•	•	•
Skin Care		•	•			
Quick 50	•	•	•			
Quick				•	•	•
Rapid 15	•	•	•	•	•	•
Bedding	•	•	•	•	•	•
15°C Wash	•	•	•	•	•	•
Delicates	•	•	•			
Memory	•	•	•			



Mixed



A programme that allows you to wash clothes very quickly even if they are made of different fabrics. This way you do not have to separate clothes and wash several loads.



Denim



With jeans in mind, this programme reduces colour fading and ensures that no possible washing powder residue remains on the clothes at the end of the wash.



Baby and Skin Care



Panasonic knows you only want the very best for your child. So choose the 'Baby Care' programme on the NA-140VG3 washing machine. It not only perfectly washes clothes, it also uses three rinse cycles to ensure that only the fabric touches your baby's sensitive skin. For people with sensitive skin, the new NA-168VG3 and NA-148VG3 appliances are equipped with the special 'Skin Care' programme.



Silk/Lingerie



A programme that takes extra care with a gentle wash action. Intermediate spinning in the rinse cycle protects textiles and prevents shrinkage, followed by a gentle final spin.



Shirts Programme



Ideal for washing shirts and blouses that easily become soiled at the collar and cuffs, the 'Shirts' programme removes common yet unsightly stains. Thanks to the extra soaking cycle, sweat stains are effectively removed so you can carry on with business in confidence.



Dedicated Fabric Care



Use the 'Wool' and 'Easy Care' programmes for wool, lace and other delicate garments. The cradle-like rotation ensures gentle washing, protecting your delicates and making them last longer.



Outdoor



Designed for synthetic and water repellent outer garments which absorb minimal moisture and dirt, this programme gently works the laundry to get it thoroughly clean.



Sportswear



The 'Sportswear' programme is just what you need for cleaning heavily soiled kits or socks with stubborn stains from mud or grass, returning them to their clean whites and bright colours. You can focus on the game and let your Panasonic washing machine take care of dirt and stains.



Available upon purchase of the following qualifying Panasonic washing machines: NA-140VG3, NA-168VG3, NA-148VG3.



NA-140VG3



- Spin Speed: 1400rpm
- 12,400 Litre Annual Water Consumption
- Top Energy Rating: A+++
- 200kWh Annual Energy Consumption (based on 220 wash loads per year)
- 3D Sensor Wash
- Sazanami Drum and Large Aperture
- Perfect Sense and HydroActive+
- Brushless Inverter Motor with 10 Years Warranty
- LED Display (Quick 50, Rapid 15, Baby Care, Silk/Lingerie)
- Quiet Operation: Spin Noise Level of 71 dB
- **Will Take up to 50 Shirts in One Wash Load**

NA-168VG3



Same Features as NA-140VG3

- Spin Speed: 1600rpm
- 9,750 Litre Annual Water Consumption
- 155kWh Annual Energy Consumption (based on 220 wash loads per year)
- LED Display (Quick 50, Rapid 15, Skin Care, Denim, Outdoor)
- Quiet Operation: Spin Noise Level of 71 dB
- **Will Take up to 40 Shirts in One Wash Load**

NA-148VG3



Same Features as NA-140VG3

- Spin Speed: 1400rpm
- 9,750 Litre Annual Water Consumption
- 150kWh Annual Energy Consumption (based on 220 wash loads per year)
- LED Display (Quick 50, Rapid 15, Skin Care, Denim, Outdoor)
- Quiet Operation: Spin Noise Level of 72 dB
- **Will Take up to 40 Shirts in One Wash Load**



WATER LEAKAGE PROTECTION



Sazanami Drum
With dimple-shaped water spouts for a gentle, efficient wash



Eco Speed Mode
Choose a fast and convenient or eco-friendly wash



HydroActive+
5 multi-directional showers deliver fast results with less consumption

NA-140VG3, NA-168VG3, NA-148VG3



A Washing Machine for Every Need

Whether you are looking for a quiet, large capacity washing machine or a no-thrills model, you can be rest assured knowing that all Panasonic washing machines are top of their class in terms of energy efficiency and convenience.



NA-148VB3



- Spin Speed: 1400rpm
- 9,900 Litre Annual Water Consumption
- Top Energy Rating: A+++
- 162kWh Annual Energy Consumption (based on 220 wash loads per year)
- Large Aperture: Easy to Load & Unload
- HydroActive
- LED Display with 12 Washing Programmes
- **Will Take up to 40 Shirts in One Wash Load**

NA-147VB3



- Spin Speed: 1400rpm
(also available in 1200rpm: NA-127VB3)
- 9,240 Litre Annual Water Consumption
- Top Energy Rating: A+++
- 162kWh Annual Energy Consumption (based on 220 wash loads per year)
- Large Aperture: Easy to Load & Unload
- HydroActive
- LED Display with 12 Washing Programmes
- **Will Take up to 35 Shirts in One Wash Load**

Ensuring Perfectly Prepared Meals

Panasonic innovative microwave ovens are designed to enable you to quickly cook delicious and nutritious meals the whole family will love.



the **ideas**
kitchen



learn



cook



share

Introducing the Ideas Kitchen

The site features hundreds of other recipes and great tips that can allow you to become a gourmet chef in next to no time at all!

www.theideaskitchen.co.uk

Special Features



Inverter Technology

INVERTER Unique to Panasonic, Inverter technology gives constant cooking energy on medium and low power settings instead of switching on and off as traditional microwave ovens do. It provides an even cooking process for your food, preserving full texture and flavour.



Flatbed

FLATBED The innovative Flatbed design provides more usable space which means greater flexibility on the size and shape of dishware that can be used – whether oval, rectangular or square. Furthermore, the Flatbed makes cleaning easier than ever.

Flatbed Combination Ovens can be easily cleaned thanks to the catalytic self cleaning back plate. This self-cleaning process takes place when the convection oven is in use and is performed as a continuous process so there is no build up of food or grease.

In 'Convection' mode, the two shelves provide all the versatility of a traditional oven - perfect for batch baking or cooking large dishes of food that would not normally fit on the turntable.



Chaos Defrost

CHAOS DEFROST Chaos Defrost is a quick and efficient defrosting system which uses random pulses of microwave power. Chaos Defrost raises the temperature of the frozen food quickly and evenly and allows the heat to transfer to the centre of the food in a more constant way. Chaos Defrost is available on all Panasonic Inverter Microwaves.

Eco Mode



Panasonic microwave ovens use a range of processes to save energy consumption, such as Eco Mode. When the microwave is set to Eco Mode, it uses only 0.09W of energy in stand by.

Slimline Combi



Space in your kitchen is always at a premium, especially when preparing ingredients. Our award winning Slimline Combi Ovens take up 20% less space on the work surface than a comparable 27L Combination oven.

This is possible because we have moved the fan to the roof of the oven rather than at the back reducing the depth of the oven by 20%.

Panacrunch Pan



Panacrunch is a pan accessory included in our 27 litre Grill Microwave Ovens. The Panacrunch Pan together with 'Microwave', 'Grill' or 'Convection' modes provides crunchy and crispy results every time. It is ideal for a variety of food types, such as pizza and quiche.

Versatility Meets High Performance

The Panasonic Combination Microwave Oven sets the tone for the entire range of combination microwave ovens. By bringing together convection, grill and microwave functionality in one product, Panasonic ensures that your meal choice is endless!



NN-CF771SBPQ

- Flatbed Combination Oven
- Flatbed Design
- Family Size 27 Litre Capacity
- Fan Assisted Convection Oven
- 1000W Power Output
- Inverter Technology
- Stainless Steel Finish
- Optional: Trim Kit NN-TKF71S in Stainless Steel



NN-CF771S



NN-CF778SBPQ

- Flatbed Large Dish Capacity
- Family Size 27 Litre Capacity
- Fan Assisted Convection Oven
- 2 Shelf Cooking
- Inverter Technology
- Energy Save
- Metallic Silver



NN-CF760MBPQ

- Flatbed Large Dish Capacity
- Family Size 27 Litre Capacity
- Fan Assisted Convection Oven
- 2 Shelf Cooking
- Inverter Technology
- Energy Save
- Metallic Silver

NN-CF750WBPQ

- Same Features as NN-CF760MBPQ.
Available in Metallic Crisp White Finish.





NN-CT890SBPQ

- Sensor Cook Large Capacity Oven
- Large Family Size 32 Litre Capacity
- Fan Assisted Convection Oven
- Inverter Technology
- 1000W Power Output
- Energy Save
- Stainless Steel



NN-CT880MBPQ

- Sensor Cook Large Capacity Oven
- Large Family Size 32 Litre Capacity
- Fan Assisted Convection Oven
- Inverter Technology
- 1000W Power Output
- Energy Save
- Metallic Silver Finish

NN-CT870WBPQ

- Same Features as NN-CT880MBPQ.
Also available in Crisp White Finish



NN-CT890SBPQ, NN-CT880MBPQ, NN-CT870WBPQ

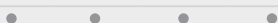

Space Saving Style

The range of stylish Panasonic Slim Combi microwaves is ideal for kitchens with limited space. Up to 20% space saving, they offer three cooking methods – convection, grill and microwave.



NN-CT579SBPQ

- Slimline Combi Microwave
- Family Size Capacity 27 Litre
- Slim Design Creates 20% Space Saving on Worktop
- 100°C-220°C Convection Heater
- 1000W Power Output
- Energy Save Mode
- Stainless Steel Finish



NN-CT569MBPQ

- Slimline Combi Microwave
- Family Size Capacity 27 Litre
- Slim Design Creates 20% Space Saving on Worktop
- 100°C-220°C Convection Heater
- 1000W Power Output
- Energy Save Mode
- Metallic Silver Finish



NN-CT559WBPQ

- Same Features as NN-CT569MBPQ.
Also available in Crisp White Finish



Microwave With Traditional Results

This range of ovens crisps and toasts like an ordinary grill but with all the benefits of a microwave oven.



NN-GD560MBPQ

- Microwave Oven with Enhanced Grill Power
- Family Size 27 Litre Capacity
- Inverter Technology
- 900W Power Output
- Quartz 1300W Grill Power
- Panacrunch Pan
- Metallic Silver finish



NN-GD379SBPQ

- Family Grill Microwave Oven
- Inverter Technology
- 20 Litre Capacity
- Quartz 1100W Grill Power
- Energy Saving Mode
- Stainless Steel finish



NN-K189MMBPQ

- Compact Design Touch Panel
- Compact 16 Litre Capacity
- 1000W Grill Power
- Auto Defrost
- Metallic Silver finish



NN-GD560MBPQ	•	•	•	•	•
NN-GD379SBPQ	•		•	•	
NN-K189MMBPQ			•		



NN-SF460MBPQ

- Flatbed with Large Dish Capacity
- Family Size 27 Litre Capacity
- Inverter Technology
- 900W Power Output
- Chaos Defrost
- Turbo reheat
- Metallic Silver finish



NN -ST479SBPQ

- Sensor One Touch Cooking
- Family Size 27 Litre Capacity
- Inverter Technology
- Sensor Cook
- 900W Power Output
- Chaos Defrost
- Turbo Reheat
- Stainless Steel finish



NN-SF460MBPQ
NN -ST479SBPQ

•	•	•
•	•	•

All-Round Convenience and Functionality

Reheat and cook food to perfection! Flexible features and intelligent Inverter technology make these microwave ovens your essential daily kitchen helper. Cooking has become so easy.



NN-SD460MBPQ

- Inverter Technology Easy to Use
- Family Size 27 Litre Capacity
- 900W Output Power
- Chaos Defrost
- Stainless Steel Lining



NN-SD279SBPQ

- Inverter Technology Auto Defrost
- 22 Litre Capacity
- 850W Power Output
- Energy Save
- Stainless Steel Finish

NN-SD440WBPQ

- Same Features as NN-SD460MBPQ.
Also available in Crisp White Finish

NN-SD269MBP/ NN-SD259WBPQ

- Same Features as NN-SD279SBPQ.
Also available in Metallic Silver/Crisp White Finish



NN-SD460MBPQ, NN-SD440WBPQ	•	•	•	•
NN-SD279SBPQ, NN-SD269MBPQ, NN-SD259WBPQ	•	•	•	•



NN-E289MMBPQ

- Compact Microwave
- 19 Litre Capacity
- 700W Power Output
- Auto Weight Defrost
- Energy Save Mode
- Wipe Clean Acrylic Lining
- Metallic Silver Finish



NN-E279WMBPQ

- Compact Microwave
- 19 Litre Capacity
- 700W Power Output
- Auto Weight Defrost
- Energy Save Mode
- Wipe Clean Acrylic Lining
- Crisp White Finish

NN-E289BMBPQ

- Same Features as NN-E289BMBPQ.
Also available in Black



NN-E289MMBPQ, NN-E289BMBPQ, NN-E279WMBPQ

•

•

Enhancing Life with Healthy, Homemade Bread

Choose your own wholesome ingredients, the Panasonic breadmaker does the rest! The new models have many additional baking modes to ensure you enjoy healthy bread using a variety of cereals and flours. Surprise your family with homemade jam and compote, made by a breadmaker.



SD-ZB2502BXC

- Comprehensive Bake Programmes (including Basic White, Whole Wheat, 100% Rye, 100% Gluten-Free, Brioche, etc.)
- Yeast Dispenser
- Raisin/Nut Dispenser
- Speciality Mode (100% Spelt Flour Bread)
- Jam and Compote Modes
- 3 Loaf Sizes: Medium, Large or Extra Large
- Bake-Only Mode
- Rapid Bake: 1H 55Min
- 13 Hour Delay Timer
- 10 Minute Power Interruption Protection



SD-2501WXC

- Same Features as SD-ZB2502BXC, except for the Yeast Dispenser

SD-2500WXC

- Same Features as SD-ZB2502BXC, except for the Yeast Dispenser, Raisin/Nut Dispenser and Rye Bread Programme



Must Have Features for Your Bread Baking Needs



Diamond-Flouro-Coated Bread Pan No more sticky pans, the surface of the bread pan and blade is covered with diamond particles which are twice as tough and scratchproof as conventional pans.



Gluten-Free Programme The 'Gluten-Free' programme allows you to bake 100% 'Gluten-Free' loaves using a wide range of gluten-free bread mixes. It produces the best baking results.



Raisin/Nut Dispenser Using the automatic 'Raisin/Nut Dispenser', you can easily add additional ingredients to your recipe.

Only SD-ZB2502BXC and SD-2501WXC.



Brioche Programme Thanks to the 'Brioche' programme, you can bake delicious brioche loaves.



Jam and Compote Mode Using the automatic 'Jam and Compote' mode, you can easily and quickly prepare fruit jam and compote at home.



Yeast Dispenser Unique to Panasonic, the 'Yeast Dispenser' minimises the risk of failure for baking. It drops the yeast automatically at the optimum time.

Only SD-ZB2502BXC.

Making Home a Cleaner Place

Thanks to the HEPA Filter and unique ECO-MAX engine, high performance Panasonic vacuum cleaners keep the dirt in the vacuum and away from your family, while ensuring less energy consumption at the same time.



Unrivalled Suction with Maximum Efficiency

The new Panasonic upright bagless vacuum cleaner's unique ECO-MAX motor uses energy more efficiently to deliver unrivalled suction power. It's part of a smart new generation of home appliances from Panasonic that uses innovation and energy more inventively for better performance.



1500W MAX.INPUT 350W SUCTION

ECO-MAX

Panasonic vacuum cleaners provide superior suction power using the high efficiency ECO-MAX engine with a patented 3D Inducer Fan. The result is more performance with less energy consumption.

HEPA Filter

These filters offer superior cleaning and durability. Unlike normal filters, the micro thin membrane traps dust and dirt on the surface, while allowing air to pass through more efficiently, reducing the chance of clogging.



Washable for Easy Cleaning



Small Niches Easily Reachable



Furniture, Walls, Ceilings



With Foot Pedal

Easy to Use

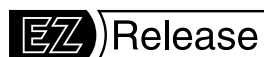

The EZ Release system makes vacuuming your home easier and more efficient than ever. It is extremely flexible: by using the foot pedal, you can quickly switch between floor and furniture nozzles. Even cleaning hard to reach areas, such as behind furniture or on the walls and ceiling.

Mobility

Optimal mobility and furniture protection, the latest generation of Panasonic vacuum cleaners feature three 360° rotatable, rubber-coated wheels that are kind to your floors.



Clean Air



The HEPA Filter offers superior cleaning and durability. Unlike conventional filters, this advanced filter's micro thin membrane removes up to 99% of the dust, dirt and irritants from the exhaust to deliver the cleanest air possible. Plus, it traps dust and dirt on the surface, while allowing air to pass through more efficiently – reducing the chance of clogging and ensuring long lasting use.



MC-UL594SP47

- ECO-MAX Motor with 1500W
- 350W Suction Power (23% motor efficiency)
- Capacity: 2.5 Litre
- Hose: 3.5m
- Cord: 7.5m
- All Floors
- High Efficiency HEPA H10 Air Filtration System
- Lightweight: 8.8kg
- 15 Stair Hose Reach



Truly Clean

Realising high suction power with maximum efficiency, Panasonic vacuum cleaners take the effort out of cleaning. Features like ECO-MAX motor, HEPA Filter and multiple surface nozzles make cleaning a breeze.



MC-UL592WP47

- ECO-MAX Motor with 1400W
- 300W Suction Power (21% motor efficiency)
- Capacity: 2.5 Litre
- Hose: 3.5m, Cord: 6m
- All Floors
- High Efficiency HEPA H10 Air Filtration System
- Lightweight: 8.6kg
- 13 Stair Hose Reach



MC-UL596XP47 Available June 2011

- 1500W / 350AW
- ECO-MAX Motor (23% Motor Efficiency)
- Capacity: 2.5 Litre
- Hose: 3.5m, Cord: 8.5m
- All Floors
- High Efficiency HEPA H10 Air Filtration System
- Lightweight: 8.8kg
- 15 Stair Hose Reach
- Pet Hair Turbo Brush
- Manual Suction Control





MC-UG304KP47

- 2000W Motor
- 290W Suction Power
- 6.1 Litre Dust Bag Sapacity with Bag Full Indicator
- Edge to Edge Cleaning and Auto Height Adjustment
- Lightweight at Only 6.3kg
- Comes with Crevice Nozzle, Dusting Brush and Extension Tube, All Stored On-board
- 5 Replacement Dust Bags Included



MC-UG302WP47

- 1900W Motor
- 260W Suction Power
- 6.1 Litre Dust Bag Capacity with Bag Full Indicator
- Edge to Edge Cleaning and Auto Height Adjustment
- Lightweight at Only 6.3kg
- Comes with Crevice Nozzle, Dusting Brush and Extension Tube, All Stored On-board
- 5 Replacement Dust Bags Included

Truly Clean

Realising high suction power with maximum efficiency, Panasonic vacuum cleaners take the effort out of cleaning. Features like ECO-MAX motor, HEPA Filter and multiple surface nozzles make cleaning a breeze.



MC-CG695ZP47

- ECO-MAX Engine with 1300W
- 450W Suction Power (35% motor efficiency)
- Less Noise with 72dB
- High Efficiency HEPA H10 Air Filtration System
- Lightweight: 5.0kg
- High Performance 2 Step Nozzle with EZ Release Multiple Surface Cleaning
- 3 Independent Soft Casters (rear & front)



MC-CG691RP47

- ECO-MAX Engine with 1300W
- 450W Suction Power (35% motor efficiency)
- High Efficiency HEPA H10 Air Filtration System
- Lightweight: 5.0kg
- High Performance 2 Step Nozzle
- 3 Independent Soft Casters (rear & front)



Look Your Best Effortlessly

The secret to looking beautiful and handsome, is effortless and relaxed grooming – Panasonic Personal Care products for men and women offer you the very best to always look great.



A Comfortable, Close Shave Is Essential

Panasonic men's shavers are designed to perfectly follow the curves of your face. Equipped with a combination of intelligent and innovative features, they ensure a close and comfortable shave every day.

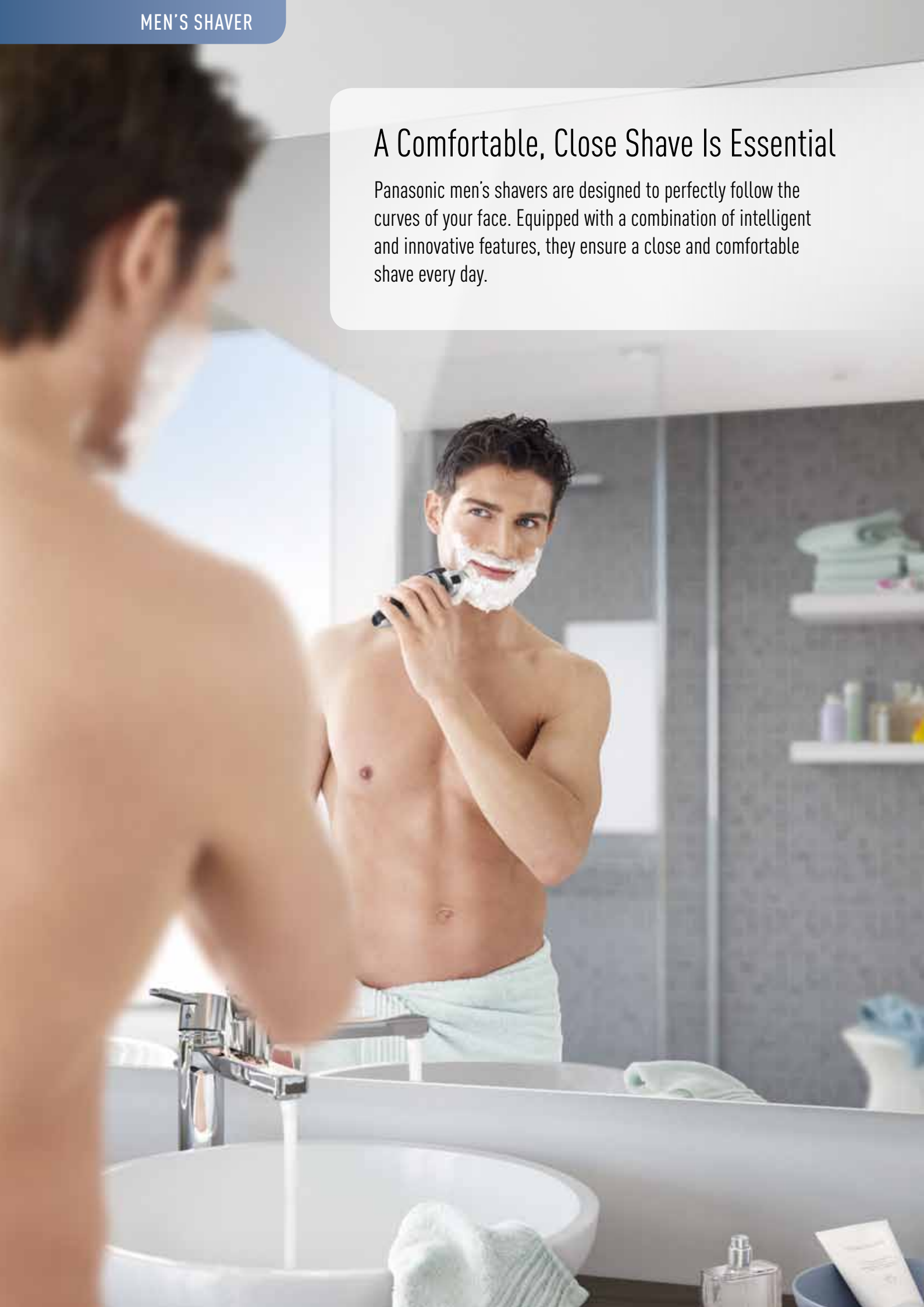

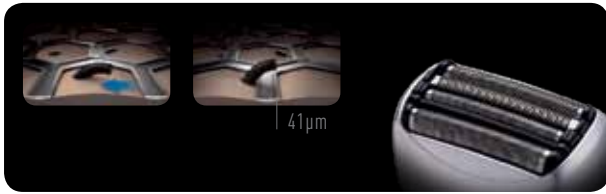

A Gentle Shave with Four Blades



The conventional 3-blade shaver foil employs an additional extra thin finishing foil. The outer finishing foil, 41µm at its thinnest, closely shaves difficult-to-cut facial hair, while the other standard 60µm thick outer foils protect the skin for a smooth shave.

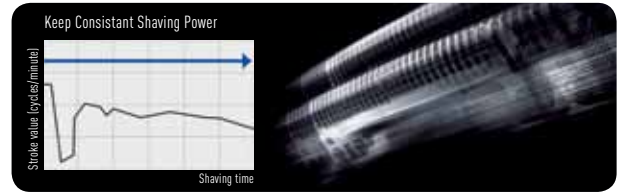

For a Fast Shave



At up to 14,000cpm, the Panasonic Linear Motor Drive offers the world's fastest motor speed¹ from start to finish. This advanced technology always maintains maximum power thanks to automatic speed control, even in dense stubble.

Smooth Results



While the shaver's flexible active head constantly keeps contact with your facial skin, a miniature built in motor (ES-LA93) squeezes out the hairs via micro-impulse vibrations, so you enjoy our smoothest results ever!

For Facial Contours



The shaver's multi-pivoting head adapts to the contours of your face by pivoting up and down as well as left and right, so you have an excellent shave regardless of the shape of your face.

Extremely Sharp

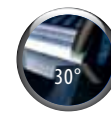

To give you the sharpest shave possible, the latest Panasonic men's shavers feature 30° nano-polished inner blades. They have been sharpened to a 30° angle knife edge for an even more precise and close shave.

Shaver Categories

	Maximum Comfort	Fast Clean-Cut	Perfect Clean-Cut	Easy Clean-Cut
Number of Blades				
WET or DRY Shaving Shave under the shower or with shaving lather, oil or simply use dry				
Gentle on the Skin Pivoting head adapts to the contours of your face				
Precise Shave Blades are sharpened to 30° angle knife edge				
Fast Through Tough Stubble Extra thin finishing foil for hard-to-cut stubble				
Consistent Shaving Power The premium linear motor ensures maximum motor power through dense beards from start to finish				

¹ According to Panasonic testing (January 2011).



ES-LA93-K

- Can Be Used for Wet or Dry Shaving
- Washable, 100% Waterproof
- 4-Blade Cutting System with Finishing Foil
- Multi-Flexible Active Head with LOCK/FLEX Function
- Active Vibrating Head Squeezes Out Stubble
- Curved Arc Foil and Sharpest 30° Nano-Edged Inner Blades
- Automatic Cleaning and Charging System
- Linear Motor with 14,000CPM
- 45 Minutes Cordless Use, 1h Charge (Lith-Ion)
- LCD Display (blue)

ES-LA63-S

- Same features as ES-LA93-K, except without Automatic Cleaning and Charging System

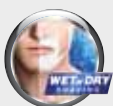

Four Blades For Maximum Shaving Comfort

Experience the fastest, closest and smoothest shavers that Panasonic has to offer. The flagship series give shaving a new dimension: the outstanding 4-blade cutting system combined with the full power of Panasonic Linear Motor technology provide extra strength for shaving dense beards.



ES8249S

- Can Be Used for Wet or Dry Shaving
- Washable, 100% Waterproof
- 4-Blade Cutting System with Finishing Foil
- Curved Arc Foil and Sharpest 30° Nano-Edged Inner Blades
- Multi-Directional Pivoting Head with SOFT/LOCK Function
- Automatic Cleaning and Charging System
- Linear Motor with 13,000CPM
- 45 Minutes Cordless Use, 1h Charge (Lith-Ion)
- LCD Display



ES-RF41-S

- Can Be Used for Wet or Dry Shaving
- 4-Blade Cutting System with Finishing Foil
- Curved Arc Foil and Sharpest 30° Nano-Edged Inner Blades
- Multi-Directional Pivoting Head
- 65 Minutes Cordless Use (about 3 weeks), 1h Charge (Lith-Ion)
- 5-LED Indicator with Charging Stand

ES-RF31-S

- Same features as ES-RF41-S, except for Charging Stand featuring 3-LED Indicator





ES-RT81-S

- Can Be Used for Wet or Dry Shaving
- Washable, 100% Waterproof
- 3-Blade Cutting System
- Sharpest 30° Nano-Edged Inner Blades
- Multi-Directional Pivoting Head

- Automatic Cleaning and Charging System
- 45Min Cordless Use (about 2 weeks), 1H Charge
- LCD Display



ES-RT51-S

- Same features as ES-RT81-S, except without Automatic Cleaning and Charging System



Essential Features Ensure Easy Shaving

Thanks to the wide range of Panasonic Wet / Dry men's shavers, you are sure to find the product that is just right for you. From the essential 2-blade shaver to the ergonomically engineered 3-blade model, you are assured a fast, smooth shave every time.



ES-RT31-S

- Can Be Used for Wet or Dry Shaving
- Washable, 100% Waterproof
- 3-Blade Cutting System
- Sharpest 30° Nano-Edged Inner Blades
- Multi-Directional Pivoting Head
- 45Min Cordless Use (about 2 weeks), 1H Charge
- 2-LED Charge Indicator



ES-RW30-S

- Ideal for Light to Mid Stubble
- Can Be Used for Wet or Dry Shaving
- Washable, 100% Waterproof
- 2-Blade Cutting System
- Multi-Directional Pivoting Head
- 21Min Cordless Use (1 week)
- Charging Station

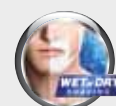

A Perfect Look Makes the Difference

Whatever your personal style or grooming preferences, Panasonic offers a whole range of products for trimming and shaping your hair, beard, facial or body hair. High quality, strong and precise blades, in combination with an advanced ergonomic design resulting in a perfect trimming experience.



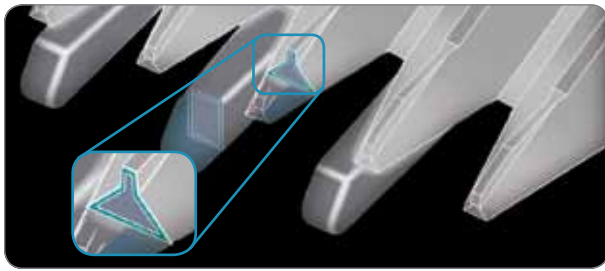

Precise, Fast Results



Hair Clippers with high precision blades, sharpened to a 45° angle knife edge, and high motor power provide maximum cutting performance of up to 30,000 hairs/sec¹ – just like a professional hair stylist at home. Panasonic Beard Trimmers feature high quality stainless steel blades for extra long-lasting blade life.

¹ According to Panasonic testing.



Easy Cleaning



The convenient Washable function makes caring for your Panasonic product easy, both in terms of cleaning and maintenance, particularly after each use.



Customised Cutting Length















For easy control, the extra accurate Quick Dial allows you to adjust the cutting length interval in up to 1mm steps. Also, the dial is fixed during use to avoid any comb movement, allowing for a safe, precise cut.

Ready for Global Travellers



Whether you travel on business or enjoy life at home, Panasonic hair clippers and beard trimmers provide automatic universal voltage of 100V to 240V. So you can always take it along with you and look perfectly groomed.

			HAIR	FACE	FACIAL	BODY
	Hair Clipper Ensures strong, precise cuts		Full Haircut 			
	Beard Trimmer Maintains beard styles			Full Beard, Moustache, 3 Day Stubble, Contours 		
	Facial Trimmer Precisely shapes unwanted hair				Nose, Eyebrow, Ear Hair 	
	Body Shaver Sensitively cuts unwanted hair			Moustache, Stubble, Contours 		Close Shaving and Trimming, Chest, Back 

Perfect Grooming Results at your Convenience

It is a matter of control, precision and comfort to trim like a professional hair stylist at home. That is why Panasonic washable hair clippers with 1mm step control cuts hair precisely, while your individual beard style, whether it be 3 day stubble, a full beard or traditional moustache, can be maintained with precision.



ER-GC50-K

POWER HAIR CLIPPER

- Washable
- 25 Different Cutting Lengths from 1mm to 25mm | 0.5mm without Comb
- 40mm Width Fixed Blade
- 2 Attachment Combs
- Cord / Cordless
- 40Min Cordless Use



ER2061K

BEARD TRIMMER

- Stainless Blades
- Easy-to-Adjust Comb with Quick Dial
- 12 Different Cutting Lengths from 2mm to 18mm
- Cord / Cordless
- 50Min Cordless Use



ER2403K

BEARD TRIMMER

- Can Be Used for Wet or Dry Shaving
- Washable, 100% Waterproof
- Stainless Blades
- 5 Different Cutting Lengths from 3mm to 15mm
- Battery Operated





ER-GY50-S

BODY SHAVER

- For Wet or Dry Use Even Under the Shower
- Washable, 100% Waterproof
- Stainless Blades
- Body Trimming – 3 Different Lengths from 3mm to 9mm
- Beard Trimming – 9 Different Lengths from 2mm to 14mm
- Body Shaving – Foil Shaver
- Pop-Up Trimmer
- 30Min Cordless Use



ER-GN30-K

FACIAL HAIR TRIMMER

- Precision Cutting System with Dual-Edge Blades for Nose, Ear and Facial Hairs
- Stainless Blades with Rotating Cutting System
- Smart Wash System
- Battery Operated (AA not included)





Smooth Skin Feels Good

Panasonic exchangeable head Wet or Dry epilators and lady shavers bring out your natural beauty without compromising on gentle care. Smooth skin that is silky to the touch always feels good and healthy.





ES-WD72-P

4-IN-1 ALL OVER EPILATOR AND SHAVER

- Can Be Used Wet or Dry Even in the Comfort of your Bath or Shower - 100% Waterproof
- 2-Disc Epilation with 48 Tweezers
- Large Epilator Head for Legs / Arms
- Small Epilator Head for Underarms / Bikini Zone
- Exchangeable Shaving Head with Trimmer for All Areas
- Bikini Comb
- Gentle Cap with Skin Protector
- Beginner Cap
- Up to 40Min¹ Cordless Usage, 1h Charge (Lith-Ion)

¹ Up to 40min cordless use with Gentle Cap & Beginner Cap. With standard Fast Cap, up to 30min.

Gentle Epilation for Silky Skin

Experience less pain and irritation with an innovative Panasonic Wet or Dry epilator. As discs can be covered by a skin protector, these epilators are extremely gentle even on sensitive skin. That means you can always be prepared for any situation with beautifully silky natural skin.



ES-WD52-A

3-IN-1 EPILATOR AND SHAVER

- Can Be Used Wet or Dry Even in the Comfort of your Bath or Shower - 100% Waterproof
- 2-Disc Epilation with 48 Tweezers
- Large Epilator Head for Legs / Arms
- Exchangeable Shaving Head with Trimmer for All Areas
- Bikini Comb
- Gentle Cap with Skin Protector
- Beginner Cap
- Up to 40Min¹ Cordless Usage, 1h Charge (Lith-Ion)



ES-WD42-G

2-IN-1 EPILATOR AND FOOT FILE

- Can Be Used for Wet or Dry Epilation with Foam – 100% Waterproof
- 2-Disc Epilation with 48 Tweezers
- Large Epilator Head for Legs / Arms
- Exchangeable Gentle Foot Care File to Remove Hard, Dry Skin from Feet
- Gentle Cap with Skin Protector
- Beginner Cap
- Up to 40Min¹ Cordless Usage, 1h Charge (Lith-Ion)

Long-Lasting Smooth Skin with Convenience

If you are looking for a convenient electric women's shaver, Panasonic wet / dry lady shaver is the solution for you for smooth skin for weeks.



ES2235A

LADY SHAVER

- Can Be Used for Wet or Dry Shaving
- 1 Foil Shaver Head with Trimmer
- Pop-Up Trimmer
- Washable
- Battery Operated (2 x AAA)

Essential Helpers Ensure Facial Care

Making sure you always look good with perfectly trimmed facial hair. Panasonic facial care products for women are essential for making a jaw-dropping impression every day or at any special event.



ES2113

FACIAL HAIR TRIMMER

- Stainless Micro-Fine Rounded Blades
- 2 Different Blade Types for Eyebrows and Facial Areas
- 2 Combs with 4 Different Cutting Lengths from 2mm to 8mm
- Battery Operated

Healthy Hair and Personal Style

Multi-styling straightener with curl option by Panasonic gives you the opportunity to create your own personal hair style. Regardless of what your hair type is, the photo-ceramic coated plates keep your hair healthy and its colour vibrant.



EH-HW32-K

STRAIGHTENER WITH CURL OPTION

- 3 Styling Attachments for Super Straight Hair and Medium / Large Curls
- Photo-Ceramic-Coated Plates
- Floating Upper Plate Adjusts to Hair Thickness
- 5-Level LED Indicator (130°C - 170°C)
- Quick Heat-Up
- Auto Shut-Off (After 5 minutes)
- Universal Voltage



SIDE-BY-SIDE REFRIGERATORS

Model	NR-B53V1	NR-B54X1
General Information		
Colour	Stainless Steel with anti-fingerprint	Arctic White
Gross Capacity	615l	615l
Total Net Capacity	530l	545l
Refrigerator Net Capacity	324l	339l
Freezer Net Capacity	206l	206l
No Frost Technology	•	•
Noise Level	38dB	38dB
Compressor	Inverter	Inverter
Energy Efficiency		
Energy Level	A++	A+
Energy Consumption	346kWh/year	398kWh/year
Vacuum Insulation Panel	•	-
Twin-Eco Cooling	•	•
Special Features		
Dedicated Compartments	0°C zone for meat and fish	0°C zone for meat and fish
	Vitamin-Safe 5°C freshzone	2°C zone 5°C freshzone
Anti-Bacterial Function	Hygiene Active	Hygiene Active
Main Door Display		
Display	Touch-control white LED	White LED
Independent Temperature Controls	•	•
Door Open Alarm	•	•
Vitamin-Safe Compartment	•	-
5°C Freshzone Compartment	•	•
Super Freeze Function	•	•
Hygiene Active Function	•	•
Holiday Mode	•	•
Eco Mode	•	•
Child Lock (locks Temperature Controls)	•	•
Ice/Water Dispenser		
Display	Touch-control white LED	White LED
Water, Ice Cubes, Crushed Ice	•	•
LED Lighting	•	•
Lever	Stainless Steel	Stainless Steel
Water Filter	Symbol for filter change	Symbol for filter change
Refrigerator Features		
Lighting	Front-tower LED (left & right)	Front-tower LED (left & right)
Tempered Glass Shelves	4 (height adjustable)	4 (height adjustable)
Drawer Case	0°C zone, Vitamin-Safe, 5°C freshzone	0°C zone, 2°C zone, 5°C freshzone
Door Pockets	5	5
Wine Rack	Full width for 4 bottles	Full width for 4 bottles
Deli Case	•	-
Egg Tray	•	•
Deodorising	•	•
Freezer Features		
Lighting	Front-tower LED (left)	Front-tower LED (left)
Tempered Glass Shelves	4	4
Drawer Case	3	3
Door Pockets	2	2
Ice Compartment	Integrated-type compact door	Integrated-type compact door
Freezing Capacity in 24h	15kg	15kg
Max Storage without Electricity	16 hours	16 hours
Measurements		
Height	1850mm	1850mm
Width	905mm	905mm
Depth	710mm	710mm
Weight	132kg	123kg
EAN Code	5025232532446	5025232532476

• Yes - No



2-DOOR REFRIGERATORS

Model	NR-B32FX2 / NR-B32FW2
General Information	
Body Colour	NR-B32FX2: Silver NR-B32FW2: White
Door Material	NR-B32FX2: Stainless Steel with anti-fingerprint NR-B32FW2: Arctic White
Handle	Aluminium
Display	Half-Mirror LED
Total Net Capacity	315l
Refrigerator Net Capacity	225l
Freezer Net Capacity	90l
No Frost technology	•
Noise Level	36dB
Compressor	Inverter
Energy Efficiency	
Energy Label	A++
Energy Consumption	249kWh
Special Features	
Fruit & Vegetable Compartment	Vitamin-Safe
Anti-Bacterial Function	Hygiene Active
Independent Temperature Controls	•
Refrigerator Features	
Tempered Glass Shelves	4
Drawer Case	•
Door Pockets	3
Wine Rack	• (full width)
Super Freezer	•
Lighting	LED
Vitamin Safe Compartment	• (Telescopic Rails)
Freezer Features	
Freezer Drawers	3
Ice Cube Compartment	•
Freezing Capacity in 24h	15kg
Max Storage without Electricity	16h
Programme Options	
Eco Mode	•
Holiday Mode	•
Hygiene Active (on/off)	•
Vitamin Safe (on/off)	•
Child Lock	•
Alarm	•
Demo Mode	•
Measurements	
Height	190cm
Width	60cm
Depth	65cm
Weight	82kg
Climate Class	SN-T
Reversible Door	•
Accessories	
Berry Tray	•
Egg Trays	•
Ice Cube Tray	•
EAN Code	5025232598465 / 5025232598441

The Right Place for the Appliance

Where there is a main water supply line nearby (for side-by-side refrigerator)

- Where the refrigerator will not be exposed to direct sunlight
- Where the refrigerator will be at a distance from heating appliances, cooking appliances and other sources of heat
- A location which is well-ventilated and dry
- Where the floor is sturdy and level place a solid board underneath if the refrigerator is to be installed on top of a carpet or vinyl floor. The board will protect the floor from becoming deformed and discoloured.

Provide clearance to allow heat to dissipate

Residual heat is always being emitted from the refrigerator while it is operating.

Provide sufficient clearance around the refrigerator to allow this heat to dissipate so that its cooling ability is not impaired.

FOR MODELS NR-B53V1 & NR-B54X1 ALLOW CLEARANCE:

At the rear: 50mm minimum

At the top: 30mm minimum

At the sides: 25mm minimum

When the doors are completely open

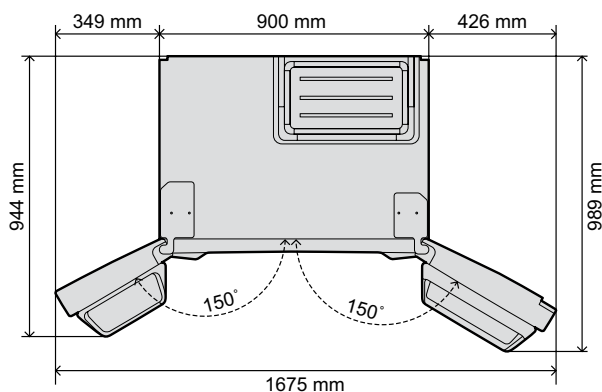

When the inside drawers have been taken out

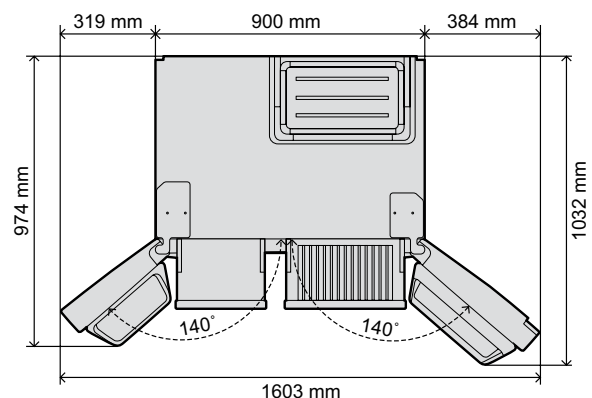

When the doors are completely open

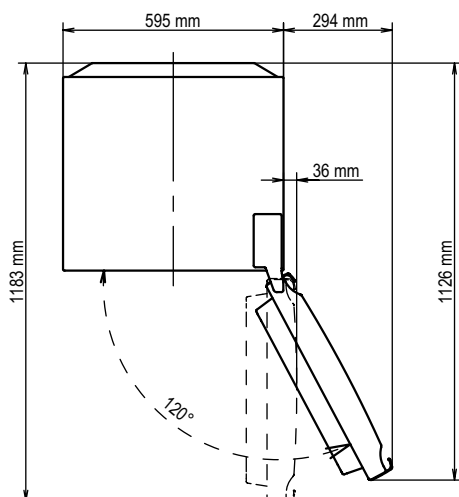

FOR MODELS NR-B32FX2 & NR-B32FW2 ALLOW CLEARANCE:

At the rear: 50mm minimum

At the top: 100mm minimum

At the sides: 20mm minimum

WASHING MACHINES



	NA-140VG3	NA-168VX3	NA-148VX3	NA-148VB3	NA-147VB3	NA-127VB3
General Information						
Body Colour	White	White	White	White	White	White
Door Ring Colour	Dark Grey Matt	Dark Grey Matt	Dark Grey Matt	Dark Grey Matt	Dark Grey Matt	Dark Grey Matt
Load Capacity	10kg	8kg	8kg	8kg	7kg	7kg
Spin Speed	1400rpm	1600rpm	1400rpm	1400rpm	1400rpm	1200rpm
Display	LED	LED	LED	LED	LED	LED
Energy Efficiency						
Energy Label ¹	A+++	A+++	A+++	A+++	A+++	A+++
Energy Consumption (kWh/annum)	200 kWh/annum	155 kWh/annum	150 kWh/annum	162 kWh/annum	162 kWh/annum	162 kWh/annum
Spin-drying Efficiency	B	A	B	B	B	B
Auto Power Off	•	•	•	-	-	-
Water Consumption						
Water Consumption L/annum ²	12,400L/annum	9,750L/annum	9,750L/annum	9,900L/annum	9,240L/annum	9,240L/annum
Special Features						
Wash Technology	3D Sensor Wash	3D Sensor Wash	3D Sensor Wash	Conventional	Conventional	Conventional
Foam Sensor	•	•	•	•	•	•
Auto Load Sensor	Perfect Sense	Perfect Sense	Perfect Sense	•	•	•
Balance Sensor	•	•	•	•	•	•
Water Circulation Pump	•	•	•	•	•	•
Motor	DC Synchronized Brushless	DC Synchronized Brushless	DC Synchronized Brushless	Brush	Brush	Brush
No. of Shower Nozzle	5 : "HydroActive +"	5 : "HydroActive +"	5 : "HydroActive +"	2 : "HydroActive"	2 : "HydroActive"	2 : "HydroActive"
Drum Design	Sazanami Drum	Sazanami Drum	Sazanami Drum	Standard	Standard	Standard
Noise level						
Silence Arch Body	•	•	•	-	-	-
Noise Level Wash	53dB	53dB	53dB	58dB	58dB	58dB
Noise Level Spin	71dB	71dB	72dB	76dB	75dB	74dB
Programmes						
Number of Programmes	16	16	16	12	12	12
15°C Wash Programme	•	•	•	•	•	•
Rapid 15	•	•	•	•	•	•
Shirts	•	•	•	•	•	•
Sportswear	•	•	•	•	•	•
Bedding	•	•	•	•	•	•
Baby Care	•	-	-	-	-	-
Skin Care	-	•	•	-	-	-
Silk/Lingerie	•	-	-	-	-	-
Outdoor	-	•	•	-	-	-
Denim	-	•	•	-	-	-
Cotton Rinse Plus	•	•	•	-	-	-
Cotton-Eco	-	-	-	•	•	•
Mixed	•	-	-	-	-	-
Delicates	•	•	•	-	-	-
Colours	•	•	•	•	•	•
Easy-care	•	•	•	•	•	•
Wool	•	•	•	•	•	•
Quick	-	-	-	•	•	•
Quick 50	•	•	•	-	-	-
Memory	•	•	•	-	-	-
Programme Options						
Eco/Speed Function	•	•	•	-	-	-
Time Delay	•	•	•	•	•	•
Extra Rinse	•	•	•	•	•	•
Pre-Wash	•	•	•	-	-	-
Easy Ironing	•	•	•	-	-	-
Security						
Leakage Protection	Water Leakage Protection	Water Leakage Protection	Water Leakage Protection	Water Leakage Protection	Water Leakage Protection	Water Leakage Protection
Child Lock	•	•	•	•	•	•
Control	Vector Inverter	Vector Inverter	Vector Inverter	Non-Inverter (ON/OFF only)	Non-Inverter (ON/OFF only)	Non-Inverter (ON/OFF only)
Cycle End Buzzer	•	•	•	•	•	•
Warranty on the motor	10 years (part only)	10 years (part only)	10 years (part only)	2 years (part only)	2 years (part only)	2 years (part only)
Dimension						
Drum Size (cm)	50cm	50cm	50cm	48.7cm	48.7cm	48.7cm
Drum Size (l)	70l	70l	70l	60l	50l	50l
Door Porthole size (cm)	34cm	34cm	34cm	33cm	33cm	33cm
Height	845mm	845mm	845mm	845mm	845mm	845mm
Width	596mm	596mm	596mm	597mm	597mm	597mm
Depth	594mm (max 625mm incl. of door)	594mm (max 625mm incl. of door)	594mm (max 625mm incl. of door)	582mm (max 602mm incl. of door)	527mm (max 547mm incl. of door)	527mm (max 547mm incl. of door)
Weight	74kg	74kg	74kg	77kg	73kg	73kg
EAN Code	5025232557783	5025232609659	5025232609598	5025232631810	5025232631827	5025232635405

• Yes - No

¹ According to the Directive 2010/30/EU
² Based on "EN60456".

The Right Place for the Appliance

Make sure that there is enough space for the appliance and ensure the openings of the base are not obstructed by a carpet.

NA-140VG3 / NA-168VG3 / NA-148VG3

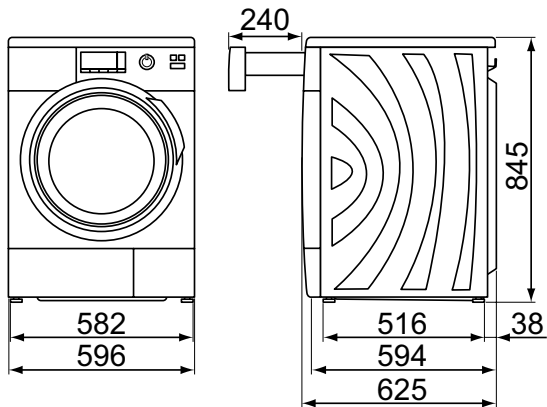

Dimension in millimetres

CAUTION

- Install the appliance on a flat, stable surface to avoid excessive vibration and noise.
- If the floor is not flat and stable, contact your local Customer Service Centre.
- Do NOT install the appliance in direct sunlight or in a place where temperatures reach freezing.
- Do NOT let metallic portions of the appliance come into contact with metal sinks or other appliances.

NA-148VB3 / NA-147VB3 / NA-127VB3

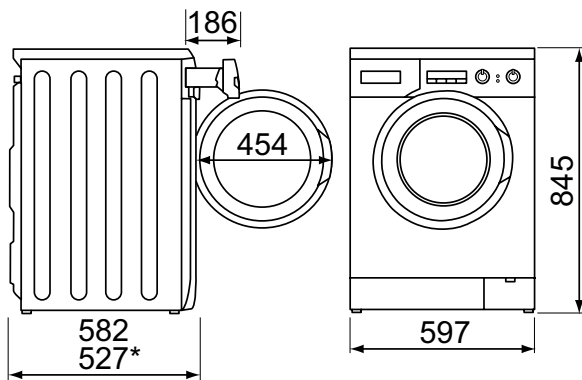

Dimension in millimetres

(*for models NA-127VB3 & NA-147VB3)

COMBI
MICROWAVES



Model	NN-CT890S	NN-CF778S	NN-CF771SBPQ	NN-CT579S	NN-CT569M	NN-CT559W
Stainless Steel	NN-CT890SBPQ	NN-CF778SBPQ	NN-CF771SBPQ	NN-CT579SBPQ	-	-
Metallic Silver	NN-CT880MBPQ	-	NN-CF760MBPQ	-	NN-CT569MBPQ	-
White	NN-CT870WBQP	-	NN-CF750WBQP	-	-	NN-CT559WBQP
Features & Benefits	Sensor Cook Large Capacity Oven 2 Shelf Cooking	Flatbed Design Large Dish Capacity Drop Down Door	Flatbed Design Large Dish Capacity Easy Cleaning	Slim Design 20% Space Saving	Slim Design 20% Space Saving	Slim Design 20% Space Saving
Eco Energy Saving	•	•	•	•	•	•
Oven Capacity	32 litre	27 litre	27 litre	27 litre	27 litre	27 litre
Fan Assisted Convection Oven	40°C then 100-250°C	40°C then 100-250°C	40°C then 100-250°C	100-220°C (Convection Heater)	100-220°C (Convection Heater)	100-220°C (Convection Heater)
Inverter Technology	•	•	•	•	•	•
Turntable	340mm	Flatbed Design	Flatbed Design	340mm	340mm	340mm
Sensor Cook	•	-	-	-	-	-
2 Shelf Cooking	•	•	•	-	-	-
Output Power	1000 W	1000 W	1000 W	1000 W	1000 W	1000 W
Grill Power	1500W Radiant	1300W Quartz	1300W Quartz	1300W Quartz	1300W Quartz	1300W Quartz
Auto Programs	21	16	16	13	13	13
Control Panel	Button / Touch	Dial / Touch	Dial / Touch	Button	Touch	Touch
Interior	Enamel Easy Clean	Stainless Steel	Stainless Steel	Stainless Steel	Stainless Steel	Stainless Steel
Child Lock	•	•	•	•	•	•
Auto Guide	•	•	•	•	•	•
Chaos Defrost	•	•	•	•	•	•
Turbo Bake	•	•	•	-	-	-
Memory	•	•	•	-	-	-
Catalytic Cleaning	Upper Plate	Back Plate	Back Plate	-	-	-
Splashguard	•	-	-	-	-	-
Wire Rack (High/Low)	•	-	-	• (High)	• (High)	• (High)
Enamel Tray & or Shelf	Tray / Shelf	Shelf	Shelf	Round	Round	Round
More Accessories	Wire Shelf	Wire Shelf & Glass Dish, Anti-Spark Ring	Wire Shelf & Glass Dish, Anti-Spark Ring	-	-	-
Interior Dimensions (W x D x H)	350 x 360 x 250	354 x 343 x 205	354 x 343 x 205	359 x 352 x 217	359 x 352 x 217	359 x 352 x 217
Exterior Dimensions (W x D x H)	530 x 508 x 344	531 x 534 x 328	529 x 494 x 326	520 x 395 x 310	520 x 395 x 310	520 x 395 x 310
Trim Kit	NN-TKAB0M/W	NN-TKF78SBP	NN-TKF715FP / NN-TKF70MFP / NN-TKF70WFP	-	-	-

• Yes - No

MICROWAVES
WITH GRILL



Model	NN-GD560M	NN-GD379S	NN-K189M
Stainless Steel	-	NN-GD379SBPQ	-
Metallic Silver	NN-GD560MBPQ	-	NN-K189MMBPQ
White	-	-	-
Features & Benefits	Inverter for even cooking Enhanced Grill Power	Inverter for even cooking Stainless Steel Design	Compact Touch Dial
Eco Energy Saving	•	•	•
Oven Capacity	27 litre	20 litre	16 litre
Output Power	900 W	850 W	700 W
Grill Power	1300W Quartz	1100W Quartz	1000 W
Inverter technology	•	•	-
Turn Table Size	340mm	245mm	245mm
Defrost	Chaos	Chaos	Auto Weight
Turbo Reheat	•	-	-
Control Panel	Touch / Dial	Buttons / Dial	Touch
Interior	Stainless Steel	Acrylic Grey	Acrylic Grey
Round Panacrunch Pan	•	-	-
Auto Guide	•	-	-
Child Lock	•	•	•
Glass Turntable	•	•	•
Round Wire Rack	•	•	•
Interior Dimensions (W x D x H)	359 x 352 x 217	325 x 330 x 191	292 x 297 x 185
Exterior Dimensions (W x D x H)	510 x 380 x 304	482 x 364 x 284	433 x 327 x 258
Trim Kit	NN-TKT59MFP	-	-

• Yes - No

MICROWAVES ONLY



Model	NN-SF460M	NN-ST479S	NN-SD460M	NN-SD279S	NN-E299S
Stainless Steel	-	NN-ST479SBPQ	-	NN-SD279SBPQ	-
Metallic Silver	NN-SF460MBPQ	-	NN-SD460MBPQ	NN-SD269MBPQ	NN-E289MMBPQ
White	-	-	NN-SD440WBPQ	NN-SD259WBPQ	NN-E279WMBPQ
Black	-	-	-	-	NN-E289BMBPQ
Features & Benefits	Easy to Use Turbo Reheat Flatbed Design	Sensor One Touch Cooking Stainless Steel Interior Easy to Use	Easy to Use Multiple Auto Programs	Easy to Use Dial Auto Defrost	Compact Size Auto Defrost
Eco Energy Saving	•	•	-	•	•
Oven Capacity	27 litre	27 litre	27 litre	22 litre	19 litre
Inverter Technology	•	•	•	•	-
Sensor Cook	-	•	-	-	-
Output Power	900 W	900 W	900 W	850 W	700 W
Defrost	Chaos	Chaos	Chaos	Auto Weight	Auto Weight
Turbo Reheat	•	•	•	-	-
Turn Table Size	Flatbed Design	340mm	340mm	245mm	245mm
Auto Programs	18	18	11 (SD440 has 9)	9	9
Control Panel	Button	Button	Touch/Dial	Buttons/Dial	Touch
Interior	Acrylic Grey	Stainless Steel	Stainless Steel (SD440 is Acrylic Grey)	Acrylic Grey	Acrylic Grey
Turntable (Glass Turntable)	•	•	•	•	•
Auto Guide	•	•	•	-	-
Child Lock	•	•	•	•	•
Interior Dimensions (W x D x H)	354 x 338 x 200	354 x 352 x 217	359 x 352 x 217	325 x 330 x 218	292 x 297 x 216
Exterior Dimensions (W x D x H)	529 x 430 x 320	520 x 395 x 310	510 x 380 x 304	482 x 350 x 284	433 x 327 x 258
Trim Kit	NN-TKF60MFP	NN-TKT59SFP	NN-TKT59MFP / NN-TKT59WFP	-	-

• Yes - No

BREADMAKER



Model	SD-ZB2502BXC	SD-2501WXC	SD-2500WXC
Colour	Stainless Steel	White	White
Safety Standard	SEMKO (Sweden)	SEMKO (Sweden)	SEMKO (Sweden)
EMC	•	•	•
Other Requirements	WEEE & RoHS	WEEE & RoHS	WEEE & RoHS
Voltage	230V	230V	230V
Plug	SHUKO-3	SHUKO-3	SHUKO-3
Capacity (bread pan)	2.5lbs (1.2kg)	2.5lbs (1.2kg)	2.5lbs (1.2kg)
Diamond Fluoro-Coated Bread Pan	•	•	•
Diamond Fluoro-Coated Kneading Blade	•	•	•
Choice of Crust Colour	•	•	•
Raisin/Nut Dispenser	•	•	-
Yeast Dispenser	•	-	-
Jam Mode	•	•	•
Compote Mode	•	•	•
Bread Programmes			
Basic White	•	•	•
Whole Wheat	•	•	•
Specialty Mode (Spelt Flour Bread)	•	•	•
100% Gluten-Free	•	•	•
French	•	•	•
Italian	•	•	•
100% Rye	•	•	-
Pizza Dough	•	•	•
Bake Only	•	•	•
Sandwich	•	•	•
Brioche	•	•	•
Colour			
Operating Panel	Black	White	White
Raisin/Nut Dispenser Lid	•	•	-

• Yes - No

UPRIGHT VACUUM CLEANER



Model	MC-UL594	MC-UL592	MC-UL596	MC-UG304	MC-UG302
Colour	Black	White	Purple	Black	White
Bagless					
Dust bin type	Single	Single	Single	-	-
Reel Clean System	-	-	-	-	-
Easy empty Function	-	-	-	-	-
Sealed dust bin	•	•	•	-	-
Capacity of dust bin	2.5 l	2.5 l	2.5 l	-	-
Filter Refreshing System	• (manual)	• (manual)	• (manual)	-	-
Dust bin full indicator	-	-	-	-	-
Bagged					
Dust Bag Capacity	-	-	-	6.1 l	6.1 l
Dust Capacity	-	-	-	4.5 l	4.5 l
Bag full indicator	-	-	-	•	•
Power					
Power control	-	-	Manual Adjust	-	-
Input power (Max)	1500 W	1400 W	1500 W	2000 W	1900 W
Input power (IEC)	1200-1300 W	1200-1300 W	1200-1300 W	1700 W	1700 W
Suction power	350 W	300 W	350 W	290 W	260 W
Sound					
Noise level (IEC)	84 dB	84 dB	84 dB	82 dB	82 dB
Nozzle Head/Agitator					
2 Motor Concept	•	•	•	-	-
Edge to edge cleaning	•	•	•	•	•
Anti-scuff bumper	•	•	•	•	•
Automatic Agitator Stop	•	•	•	-	-
Automatic height adjustment	•	•	•	•	•
Cord					
Cord Length	7.5 m	6.0 m	8.5 m	6.7 m	6.7 m
Radius of Action	8.0 m	6.5 m	9.0 m	7.0 m	7.0 m
Hose					
Hose Length	1.9 m	1.9 m	1.9 m	0.41 m	0.41 m
Hose reach	4.00 m	3.50 m	4.00 m	1.64 m	1.64 m
Hose Reach (+Wand)	5.2 m (13-step)	4.3 m (13-step)	5.2 m (13-step)	2.6 m (11-step)	2.6 m (11-step)
Total Length - Hose Reach + Power Cord	12.7 m	10.3 m	13.7 m	9.3 m	9.3 m
Body					
Net Weight	8.8 Kg	8.6 Kg	8.8 Kg	6.3 Kg	6.3 Kg
Dimensions (L x W x H)	1100 x 372 x 391 mm	1100 x 372 x 391 mm	1100 x 372 x 391 mm	1045 x 323 x 320 mm	1045 x 323 x 320 mm
Filtration					
Main Filter (bagless)	HEPA	HEPA	HEPA	-	-
Exhaust filter	HEPA	HEPA	HEPA	Electrostatic	Electrostatic
Accessories					
Item	6	4	6	3	3
Mini-turbine nozzle	•	•	•	-	-
Hard floor nozzle	•	-	•	-	-
Crevice nozzle	•	•	•	•	•
Dusting brush	•	•	•	•	•
Upholstery nozzle	-	-	-	-	-
Extension tube	• x2	-	• x2	•	•
Others					
Instant hose/wand operation	•	•	•	•	•
On-Board Tool Storage	•	•	•	•	•

• Yes - No

CYLINDER
 VACUUM CLEANER

Model	MC-CG6952P47	MC-CG691RP47
Colour	Metallic Blue	Burgundy Red
Paper Dust Bag	AMC-J2EP	AMC-J2EP
Dust Bag Type	C-17H	C-17H
Dust Bag Capacity	4.2L	4.2L
Dust Capacity	3L	3L
Bag Full Indicator	•	•
Dust Bag Expand System (Opt-Flow)	• (semi)	• (semi)
Power		
Power Control	• (variable)	• (variable)
Input Power (max)	1300W	1300W
Input Power (IEC) General	1200W	1200W
Suction Power	450W	450W
Vacuum Pressure	22kPa	22kPa
Airflow	2.1m ³ /min	2.1m ³ /min
Sound		
Noise Level	72dBA	75dBA
Extension Rods		
Magic Telescopic	• (button lock)	-
Standard Telescopic	-	•
Floor Nozzle		
EZ Release	•	-
2-Step Deluxe Class	•	-
2-Step Standard	-	•
Wheel		
Soft Caster Roller (front & rear)	•	•
Handle		
Ergonomic Type	•	•
Cord		
Cord Length	7m	5m
Radius of Action	10m	8m
Hose		
Hose Length	1.9m	1.9m
Hose Type	Blow injection	Blow injection
Body		
Net Weight	5kg	5kg
Dimensions (L x W x H)	440 x 300 x 235mm	440 x 300 x 235mm
Exhaust		
HEPA Filter	H10	H10
Accessories		
Crevice Nozzle	•	•
Dusting Brush	•	-
Upholstery Nozzle	• (on handle)	• (on handle)
Others		
Stand by Storage	-	-
Park Position Stand	•	•
360° Swivel Hose	•	•
Cord Rewind Pedal	•	•
Dust Bag Fail-Safe Mechanism	•	•
On-Board Tool Storage	• (on handle)	• (on handle)

• Yes - No

LINEAR SHAVER



Model	ES-LA93-K	ES-LA63-S	ES8249S	ES-RF41-S	ES-RF31-S
	Men's Shaver	Men's Shaver	Men's Shaver	Men's Shaver	Men's Shaver
WET/DRY Shaver	•	•	•	•	•
Shaving Head					
Blades	4	4	4	4	4
Inner Blade Angle	30° nano	30° nano	30° nano	30° nano	30° nano
Curved Arc Foil	•	•	•	•	•
Finishing Foil	•	•	•	•	•
Flex Pivoting Head	•	•	•	•	•
Active Vibrating Head	•	•	-	-	-
Multi-Flexible Active Head	•	•	-	-	-
Features					
Washable	•	•	•	•	•
Auto Cleaning System	•	•	•	-	-
Sonic Vibrating Cleaning Mode	•	•	•	-	-
Indicator	LCD	LCD	LCD	5 LEDs	3 LED
Pop-Up Trimmer	•	•	•	Slide-up	Slide-up
Linear Motor	•	•	•	-	-
RPM	14,000	14,000	13,000	N/A	N/A
Charging Time (h)	1	1	1	1	1
Usage Time (min)	45	45	45	65	65
Battery Type	Lith-Ion	Lith-Ion	Lith-Ion	Lith-Ion	Lith-Ion
Universal Voltage (100-240V)	•	•	•	•	•
Replacement Parts					
Foil	WES9165Y	WES9165Y	WES9161Y	WES9167Y	WES9167Y
Inner Blade	WES9068Y	WES9068Y	WES9068Y	WES9068Y	WES9068Y
Foil and Blade Set	WES9025Y	WES9025Y	WES9020Y	WES9027Y	WES9027Y
Detergent Cartridge	WES035	-	WES035	-	-
Logistic Data					
Material	ES-LA93-K803	ES-LA63-S803	ES8249S803	ES-RF41-S503	ES-RF31-S503
Pcs. Per Carton Box	3	5	3	5	5

SHAVER



Model	ES-RT81-S	ES-RT51-S	ES-RT31-S	ES-RW30-S
	Men's Shaver	Men's Shaver	Men's Shaver	Men's Shaver
WET/DRY Shaver	•	•	•	•
Shaving Head				
Blades	3	3	3	2
Inner Blade Angle	30° nano	30° nano	30° nano	60°
Flex Pivoting Head	•	•	•	•
Features				
Washable	•	•	•	•
Auto Cleaning System	•	-	-	-
Indicator	LCD	LCD	2 LEDs	-
Pop-Up Trimmer	•	•	•	•
Charging Time (h)	1	1	1	8
Usage Time (min)	45	45	45	21
Battery Type	Ni-MH	Ni-MH	Ni-MH	Ni-MH
Universal Voltage (100-240V)	•	•	•	-
Replacement Parts				
Foil	WES9085Y	WES9085Y	WES9085Y	WES9835Y (ES9835)
Inner Blade	WES9064Y	WES9064Y	WES9064Y	WES9860Y
Foil and Blade Set	WES9012Y	WES9012Y	WES9012Y	WES9839Y
Detergent Cartridge	WES035	-	-	-
Logistic Data				
Material	ES-RT81-S503	ES-RT51-S503	ES-RT31-S503	ES-RW30-S503
Pcs. Per Carton Box	5	5	5	5

• Yes - No

GROOMING



Model	ER-GC50	ER2061K	ER2403K
	Beard / Hair Trimmer	Beard / Hair Trimmer	Beard Trimmer
Trimmer Head			
Blades	Stainless	Stainless	Stainless
Attachments	2	1	1
Less Mess Comb	-	-	-
Thinning Function	-	-	-
Cutting Length (mm)	1-25	2-18	3-15
Comb Adjustment Steps	25	12	5
Pop-Up Trimmer	-	-	-
Features			
WET / DRY	-	-	-
Washable / Easy to Clean	•	-	•
Easy Quick Adjust Dial	•	•	-
Indicator	1 LED	1 LED	-
Cord / Cordless	•	•	-
Charging Time (h)	8	8	-
Usage Time (min)	40	50	-
Battery Type	Ni-Mh	Ni-MH	2 x AAA not included
Universal Voltage (100-240V)	•	•	-
Replacement Parts			
Trimmer Blade	WER9605Y	WER9601Y	WER9606Y
Logistic Data			
Material	ER-GC50-K503	ER2061K503	ER2403K503
Pcs. Per Carton Box	5	5	5

• Yes - No

EPILATOR



Model	ES-WD72-P	ES-WD52-A	ES-WD42-G
	Epilator	Epilator	Epilator
WET / DRY	•	•	-
Shaving System			
Epilator Head			
- for legs/arms	•	•	•
- for underarms/ bikini zone	•	-	-
Tweezing Discs	2	2	2
Tweezers	48	48	48
Gentle Cap w Skin Protector	•	•	•
Beginner Cap	•	•	•
Shaving Head	•	•	-
Foot Care Head	-	-	•
Bikini Comb	-	•	-
Features			
Washable	•	•	•
Rechargeable	•	•	•
Cord	-	-	-
Charging Time (h)	1	1	1
Usage Time (min)	401	401	401
Battery Type	Lith-Ion	Lith-Ion	Lith-Ion
Universal Voltage (100-240V)	•	•	•
Replacement Parts			
File (for foot care head)	-	-	WES2W31Y
Logistic Data			
Material	ES-WD72-P503	ES-WD52-A503	ES-WD42-G503
Pcs. Per Carton Box	5	5	5

¹ Up to 40min usage time with Gentle Cap and Beginner Cap. Standard Fast Cap up to 30min.

SKIN CARE



Model	ES2113P
	Facial Trimmer
Features	
Blade	Stainless Micro-Fine
Combs / Attachments	2 (2-8mm / 4 steps)
Flexible 'Swing Head'	•
For Eyebrows	•
For Facial Areas	•
For Bigger Eyelashes	-
For Thicker Eyelashes	-
Speed Settings	1
Battery Type	1 x AAA not included
Logistic Data	
Material	ES2113P503
Pcs. Per Carton Box	5

GROOMING



Model	ER-GN30	ER-GY50-K
	Nose / Ear Trimmer	Body Shaver
Trimmer Head		
Blades	Stainless Fine Cut	Stainless
Attachments	-	4
Cutting Length (mm)	-	2-14
Comb Adjustment Steps	-	12
Shaver Head	-	•
Pop-Up Trimmer	-	•
Features		
WET / DRY	-	•
Washable/Easy to Clean	• (SmartWash System)	•
Cord / Cordless	-	Cordless
Charging Time (h)	-	8
Usage Time (min)	-	30
Battery Type	Battery operated (1xAAA not included)	Ni-MH
Universal Voltage (100-240V)	-	•
Replacement Parts		
Trimmer Blade	-	WES9752Y (ES9752)
Foil	-	ES9775
Logistic Data		
Material	ER-GN30-K503	ER-GY50-K503
Pcs. Per Carton Box	10	5

LADY SHAVER



Model	ES2235A
	Lady Shaver
WET / DRY	•
Shaving System	
Shaving Head	•
Pop-Up Trimmer	•
Features	
Washable	•
Rechargeable	-
Charging Time (h)	-
Usage Time (min)	-
Battery Type	2 x AAA not included
Universal Voltage (100-240V)	-
Replacement Parts	
Foil	ES9775
Inner Blade	WES9752Y
Logistic Data	
Material	ES2235A503
Pcs. Per Carton Box	5

• Yes - No

STRAIGHTENER



Model	EH-HW32-K
	Straightener Ultimate Straight & Curly
Features	
Hair Type	Normal, fine, stressed, coloured, bleached and strong hair
Plates	Photo-ceramic coating
Plate Size (mm)	85 x 25
Floating Upper Plate	•
Cool Tip	•
Styles / No. of Attachments	4/3
Temperature Control	5-step LED
On / Off Button	•
Auto Shut-Off	•
Quick Heat-Up	•
Universal Voltage (100-240V)	•
Cable Length (m)	2
Watts	39 (max)
Logistic Data	
Material	EH-HW32-K825
Pcs. Per Carton Box	5

WET / DRY
MEN'S
SHAVER



Model	ES-LA93	ES-LA63	ES8249	ES-RF41	ES-RF31	ES7101	ES-RT31	ES-RT51	ES-RT81	ES-RW30
Outer Foil	WES9165Y		WES9161Y	WES9167Y		WES9085Y	WES9085Y		WES9835Y (ES9835)	
Inner Blade	WES9068Y		WES9068Y	WES9068Y		WES9064Y	WES9064Y		WES9850Y	
Foil and Blade Set	WES9025Y		WES9020Y	WES9027Y		WES9012Y	WES9012Y		WES9839Y ¹	
Detergent Cartridge	WES035	-	WES035	-	-	-	-	-	WES035	-

¹ Remark: grey-coloured foil frame.

BODY
SHAVER



Model	ER-GY50
Outer Foil	ES9775
Inner Blade	WES9850Y (ES9752)
Foil and Blade Set	-

BEARD /
HAIR
TRIMMER



Model	ER2403	ER2061	ER-GC50
Inner Blade	WER9606Y	WER9601Y	WER9605Y

RECOMMENDATIONS



Replace outer foil once every year.



Replace inner blade once every two years.



Foil and blade set.

the ideas kitchen



learn

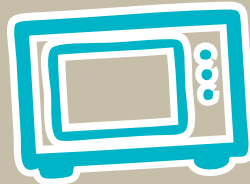

cook



share

Introducing the Ideas Kitchen

The site features hundreds of other recipes and great tips that can allow you to become a gourmet chef in next to no time at all!

www.theideaskitchen.co.uk

Visit Panasonic's new The Ideas Kitchen website, for Microwave advice, recipes, cooking tips and great offers.

Featuring one of the UK's Brightest and Creative Chefs DANIEL GALMICHE

Using his award winning recipes and quick tips, you can get the most out of your Panasonic Microwave.

The site also features hundreds of other recipes and great tips that can allow you to become a gourmet chef in next to no time at all!

Panasonic has launched an exciting new website that allows customers to become part of an online cooking community. Rich with content such as tips and tricks and recipes including videos from the Head Chef at The Vineyard, Daniel Galmiche; the site offers a unique experience for those who are passionate about cooking and getting the best possible results from their Panasonic microwave ovens and breadmakers.

As established leaders in microwave ovens and breadmakers, Panasonic's heritage in the kitchen appliance area means the new website hosts exciting recipe ideas that are tested and proven in Panasonic's Home Appliance Innovation Centre. Not only does the website offer innovative seasonal recipe ideas from highly acclaimed chef Daniel Galmiche, but also allows users to share their own ideas, tips and cooking experiences and connect with others via the forum. Users can also create their own space in "My Account" saving their favourite recipes and ideas.

As the Resident expert of Panasonic's Ideas Kitchen website, Daniel Galmiche has produced a variety of cooking tutorial videos using Panasonic's multi award-winning Flatbed Combination microwave oven, which are designed to help users create the delicious recipes in their own homes.

The Ideas Kitchen will also offer competitions where users can submit their own recipes and ideas which Daniel will expertly judge and provide valuable feedback from his 22 years of experience.

Whether you're passionate about food or just want a quick tip, Panasonic's Ideas Kitchen offers a new interactive culinary experience.



IDEAS
FOR LIVING

Panasonic Marketing Europe GmbH. The design and specification of products are constantly changing in the interest of improvement. Whilst every care has been taken in preparation of this catalogue, some changes may not have been indicated and may have occurred after publication. Please check with your Panasonic dealer for details. Panasonic Marketing Europe GmbH cannot accept responsibility for any errors and omissions.

WWW.PANASONIC.CO.UK